



MEGADYNE



MATERIAL HANDLING

INDUSTRY
BROCHURE

AM-EN



MATERIAL HANDLING

The material handling industry is all about precise positioning and placement. We know this, and that is why we support it with our extensive expertise. In our portfolio, you may find a wide range of belts, process capabilities, and material options. Major applications include: general conveying, specialty handling, and high speed bi-directional lifting.

Megadyne has been catering to your needs since 1957, designing and manufacturing power transmission belts, matched components, and complete belt systems for all types of equipment. We are a reliable partner for original equipment manufacturers and aftermarket distributors, with:

9 manufacturing plants in Europe, North America, and Asia, more than 170 Customer Solution Centres and 3 main distribution hubs around the world, able to deliver products efficiently, from large industrial sites to remote locations.

BELT PROPERTIES



MEGADYNE MEGASYNC™ RUBBER ENDLESS TIMING BELTS	
SUPPLIED AS	Endless
LENGTH	248 - 4 956 mm
WIDTH	12 - 170 mm*
PITCH	SLV2 8, SLV2 14, GLD8, GLD14, TTM8, TTM14
TENSION MEMBER	Fiberglass and Carbon fiber
FEATURES	High stability and resistance, antistatic

**Standard Width Range - Megadyne will cut to desired width upon request.*



MEGADYNE POLYURETHANE TIMING BELTS	
SUPPLIED AS	Open-ended roll - Endless - Joined - PPJ
LENGTH	MEGALINEAR 0,5 - 100 m / MEGAFLEX 1,5 - 22,77 m MEGAPOWER 225 - 2 250 mm
WIDTH	MEGALINEAR / MEGAFLEX 12 - 150 mm MEGAPOWER 6 - 75 mm
PITCH	T10, AT5, AT10, AT20, RPP14 XHP, QST8, QST14, GW14, GW20
TENSION MEMBER	Steel - HP - HF - HPF - Stainless Steel - Kevlar®
FEATURES	High resistance belts available in different lengths

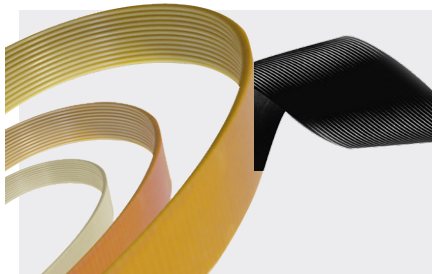

MEGADYNE PV RIBBED BELTS	
SUPPLIED AS	Endless
LENGTH	PH 584 - 1 975 mm; PJ 350 - 2 489 mm; PK 588 - 2 555 mm
WIDTH	Consult MEGADYNE
PITCH	PH, PJ, PK
TENSION MEMBER	Polyester
FEATURES	Long life and good performance



MEGADYNE V-BELTS	
SUPPLIED AS	Endless
LENGTH	Consult MEGADYNE
WIDTH	According to section
PITCH	Wrapped A, B; Raw Edge AX, BX
TENSION MEMBER	Polyester
FEATURES	Long life and good performance



MEGADYNE ROLLPOWER™	
SUPPLIED AS	Endless
LENGTH	206 - 770
WIDTH	Standard 2, 3, 4 ribs; special on request
PITCH	PJ
TENSION MEMBER	Elastic Polyamide
FEATURES	Stable tension over time, smooth running, high resistance

SPECIAL COVERS

AVAFC 60/70/85

MATERIAL	Polyurethane
COLOUR	Transparent
Excellent cut and wear resistance and good oil resistance.	

LINATEX™ RED

MATERIAL	Natural Rubber
COLOUR	Red
Cover offers high CoF, good wear resistance, good wet conditions.	

DURATAQ™/ DURATAQ™ PLUS

MATERIAL	Natural Rubber
COLOUR	Orange/Red
Cover offers a proprietary custom blended rubber which has a good CoF and very good abrasion resistance.	

NFB/NFT

MATERIAL	Nylon Fabric
COLOUR	Green
NFT/NFB offers low friction for accumulation as well as low noise benefits and is usually applied coextrusion on base belts.	

SUPERGRIP PETROL

MATERIAL	PVC
COLOUR	Petrol Green
High CoF, applicable for slight height compensation, low shock absorption capabilities. Improved adhesion even in case of moisture and dirt.	

RED GRIP

MATERIAL	PU/Synthetic Rubber
COLOUR	Red
A seamless alternative to LINATEX™. Only available on MEGAFLEX.	

METAL DRIVE COMPONENTS

Use an extensive range of pulleys and accessories like timing bars, flanges, clamping plates, couplings to design a complete drive transmission system.

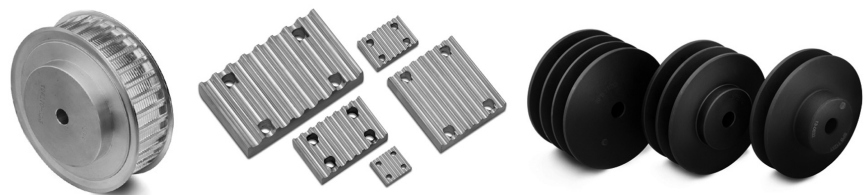

AS/RS

In the Automated Storage and Retrieval System (AS/RS), the belts are used to handle, store, and retrieve materials with precision, accuracy, and speed under a defined degree of automation.



MEGALINEAR

Thermoplastic PU 92 ShA belts, supplied as open length rolls or as endless jointed belts; available in various tooth designs and cords. (MTD14 XHP2, RPP14 XHP2, AT20).

- Constant dimension and length, improved accuracy
- Maintenance stop reduced during working time

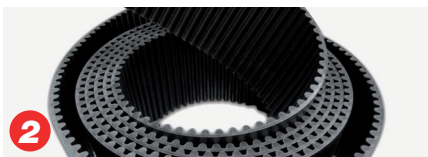
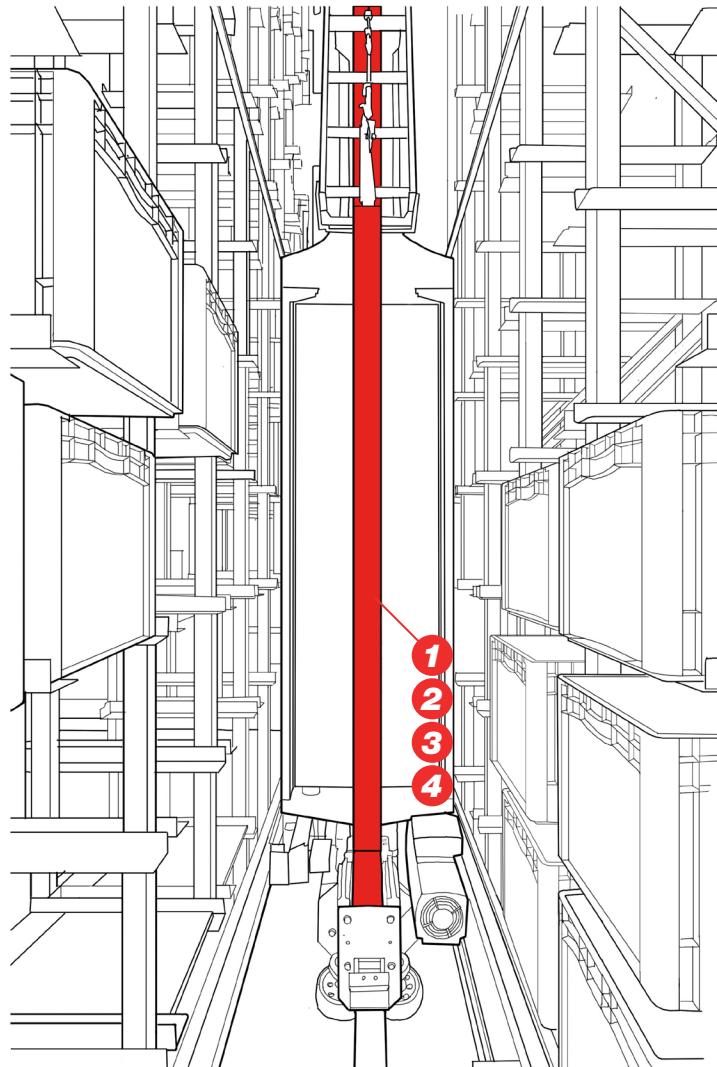

MEGALINEAR GW

High-performance thermoplastic polyurethane timing belts with Steel zinc coated cords (14M, 20M).

- High transmittable power under continuous substantial loads
- Greater breaking strength
- High tooth resistance



MEGALINEAR QST

Open-ended polyurethane timing belts, self-tracking due to the offset helical tooth design (8M, 14M).

- High torque capacity
- Low noise
- Positive engagement in Bi-directional lift applications

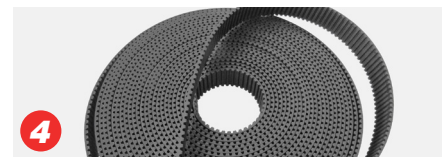

RUBBER OPEN-ENDED TIMING BELTS

Rubber base timing belts coming from sleeves for spiral cut belts and from press for straight cut belts. (RPP14 Steel).

- Very limited elongation
- Maximum traction load capacity

VERTICAL LIFT MODULES

A vertical lift module (VLM) is an enclosed system that consists of two columns of trays with an inserter/extractor in the centre. The belts located in the columns move the trays in different positions.

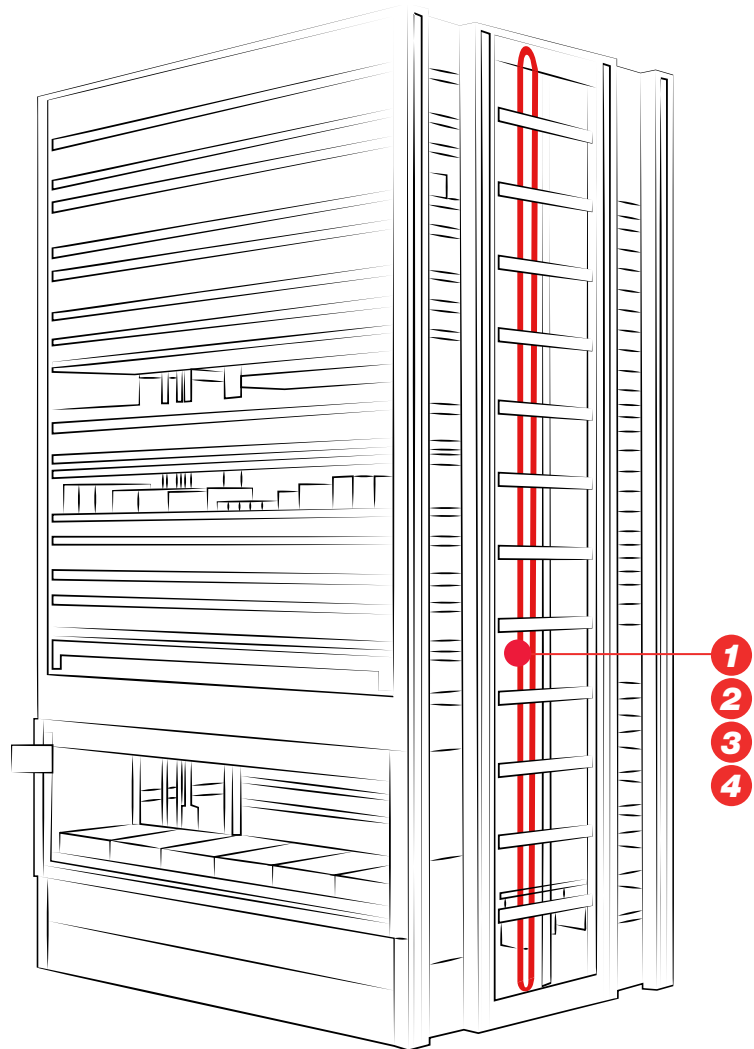

MEGALINEAR

Thermoplastic PU 92 ShA belts, supplied as open length rolls or as endless jointed belts; available in various tooth designs and cords (MTD14 XHP2, RPP14 XHP2, AT20).

- Constant dimension and length, improved accuracy
- Maintenance stop reduced during working time

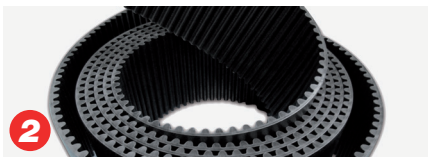

MEGALINEAR GW

High-performance thermoplastic polyurethane timing belts with Steel zinc coated cords (14M, 20M.)

- High transmittable power under continuous substantial loads
- Greater breaking strength
- High tooth resistance



MEGALINEAR QST

Open-ended polyurethane timing belts, self-tracking due to the offset helical tooth design (8M, 14M).

- High torque capacity
- Low noise
- Positive engagement in Bi-directional lift applications

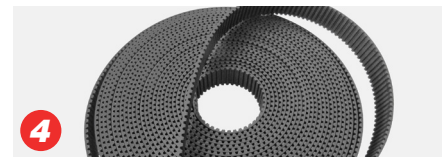

RUBBER OPEN-ENDED TIMING BELTS

Rubber base timing belts coming from sleeves for spiral cut belts and from press for straight cut belts (RPP14 Steel).

- Very limited elongation
- Maximum traction load capacity

PHARMA WAREHOUSING

Small AS/RS systems are used in pharmaceutical warehousing or carousel warehousing.



MEGALINEAR QST

Open-ended polyurethane timing belts, self-tracking due to the offset helical tooth design (8M, 14M).

- High torque capacity
- Low noise
- Positive engagement in Bi-directional lift applications



MEGADYNE MEGASYNC™ RUBBER ENDLESS TIMING BELTS

Rubber endless timing belts made of high-quality rubber compounds, and high performance tension members.

- Molded to length and pitch designation
- High performance
- Low noise



MEGALINEAR

Thermoplastic PU 92 ShA belts, supplied as open length rolls; available in various tooth designs and cords. Recommended pitches: MTD14, RPP14 XHP2, AT20.

- Constant dimension and length, improved accuracy
- Maintenance stop reduced during working time

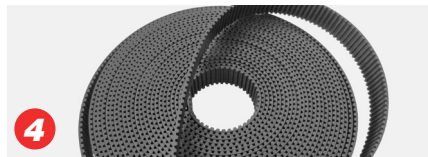
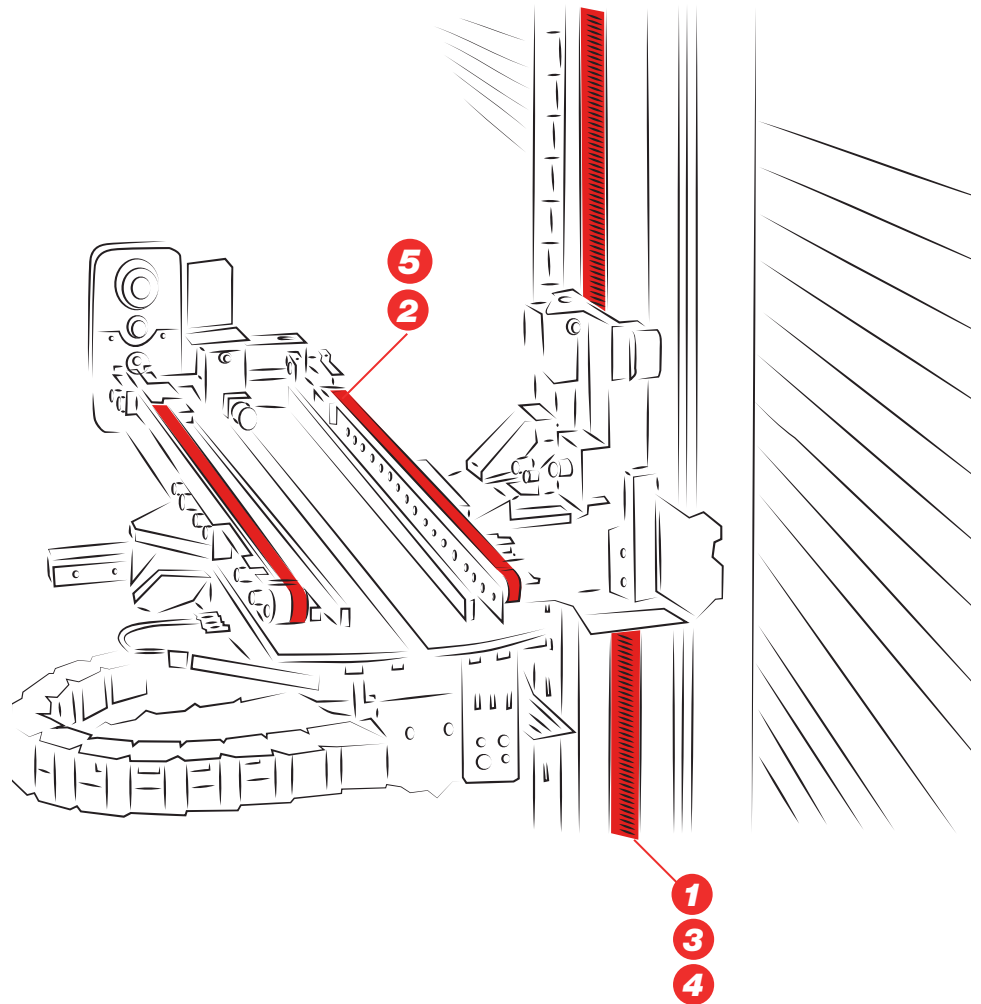

RUBBER OPEN-ENDED TIMING BELTS

Rubber base timing belts coming from sleeves for spiral cut belts and from press for straight cut belts (RPP14 Steel).

- Very limited elongation
- Maximum traction load capacity

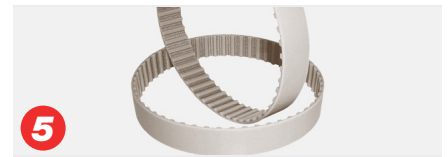

MEGAPOWER 2

Truly endless belt manufactured in thermoset polyurethane 88 ShA with high strength helically zinked Steel cord.

- High positioning precision and excellent dimensional stability
- Constant and high angular speed
- Superior wear and abrasion resistance
- Maintenance free

PALLETIZING

After the product is boxed and weighed, it is stacked, wrapped, and sent to the customer or warehoused. Megadyne Group products for this application include parallel path timing belts as well as synchronous and non-synchronous high-strength lift belts.

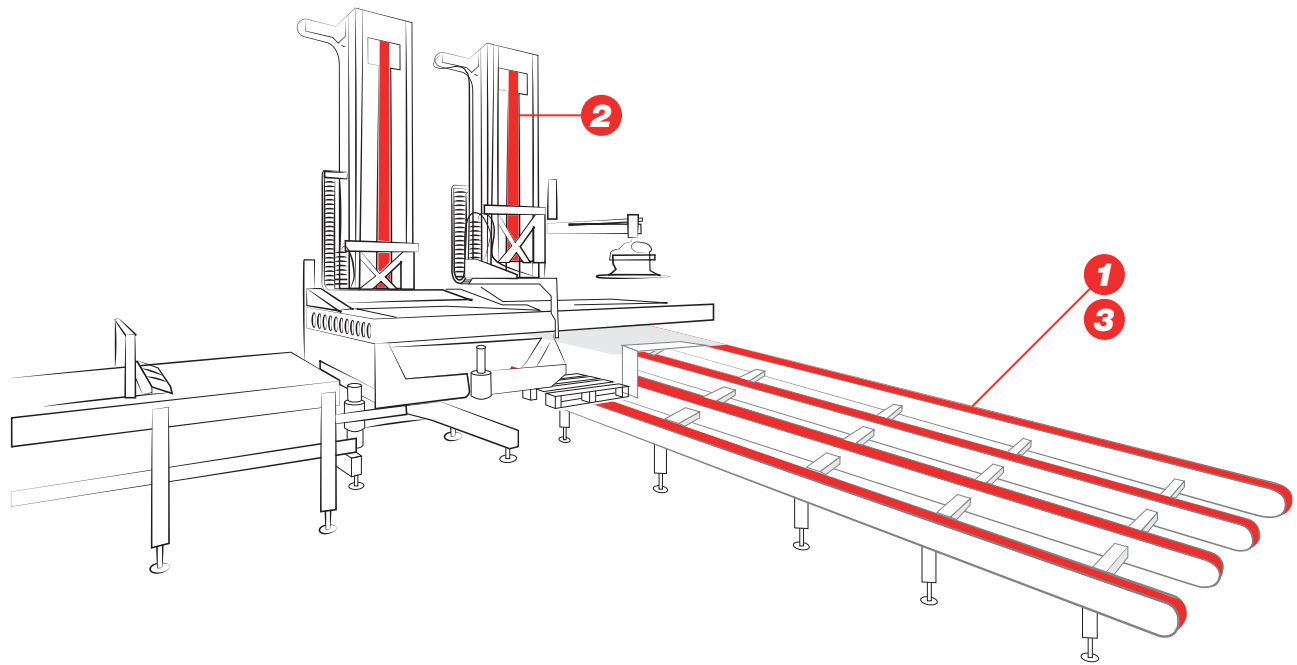

MEGALINEAR

Thermoplastic polyurethane and S & Z parallel cord, supplied as endless joined belts and available in any length.

- Suitable for high speed conveying
- High resistance to fatigue

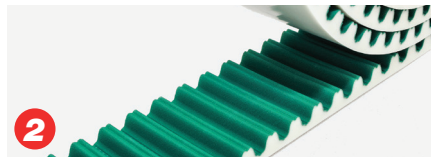

MEGALINEAR

Thermoplastic PU 92 ShA belts, supplied as open length rolls; available in various tooth designs and cords.

- High positioning precision suitable for linear movement and lifting systems
- Maximum traction load capacity



RUBBER TIMING BELTS

Rubber timing belts made of high-quality rubber compounds and spiral fiberglass tension members.

- Moulded rubber belts available in multiple lengths
- Suitable for high power transmission drives

CARTESIAN ROBOTS

A timing belt with low elongation improves positional precision of the robot arm also under high movement dynamics.

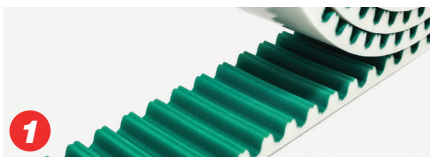
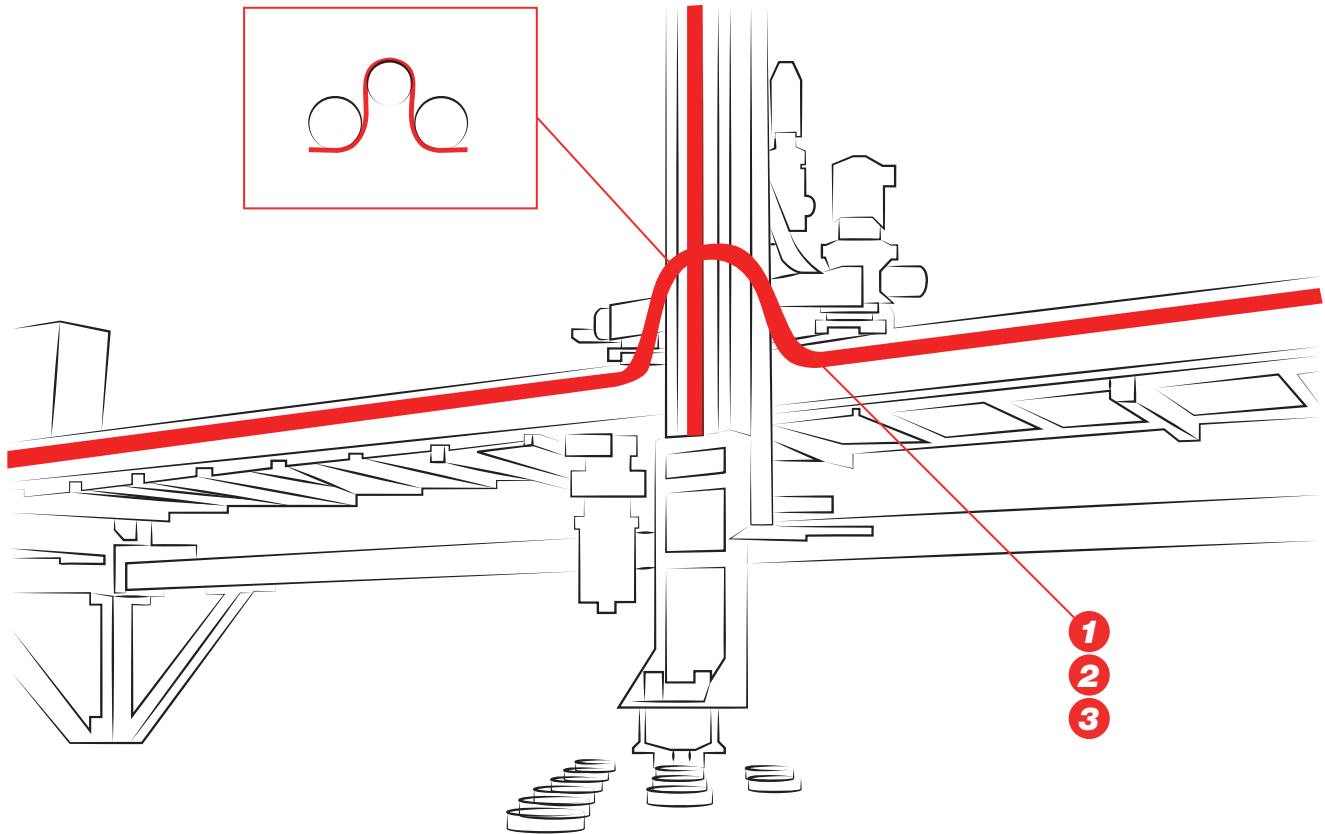

MEGALINEAR

Thermoplastic PU 92 ShA belts, supplied as open length rolls or as endless jointed belts; available in various tooth designs and cords.

Recommended pitches: RPP14, AT20

- Low elongation
- Available special clean room treatment

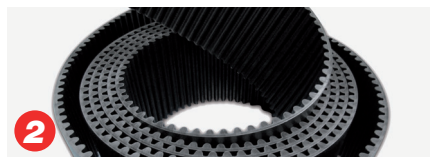

MEGALINEAR GW

High-performance thermoplastic polyurethane timing belts with Steel zinc coated cords (14M, 20M).

- High transmittable power under continuous substantial loads
- Greater breaking strength
- High tooth resistance

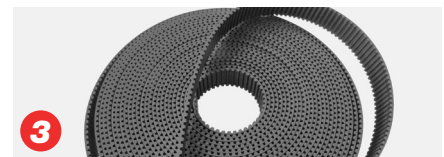

RUBBER OPEN-ENDED TIMING BELTS

Rubber base timing belts coming from sleeves for spiral cut belts and from press for straight cut belts (RPP14 Steel).

- Very limited elongation
- Maximum traction load capacity

LINEAR ACTUATORS

High strength low elongation timing belts are used to improve the positional accuracy of the carrier.

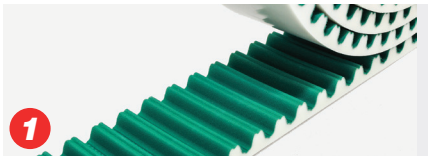
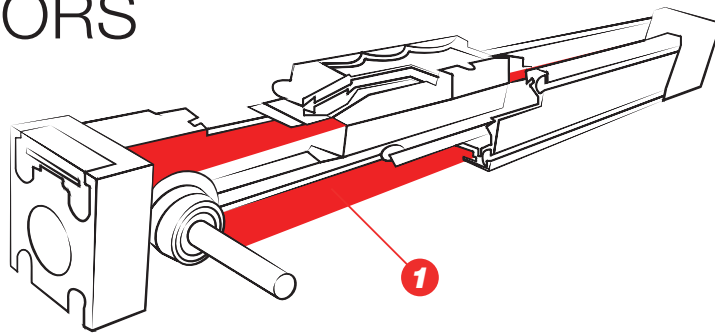

MEGALINEAR

Thermoplastic PU 92 ShA belts, supplied as open length rolls or as endless jointed belts; supplied with or without NFT or NFT/NFB; available with standard Steel or high-performance cords (MTD8, RPP8, AT5, AT10).

- Low elongation
- Available special clean room treatment

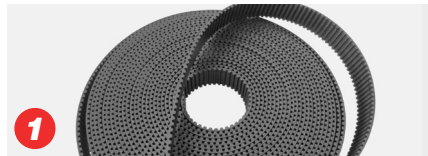

RUBBER OPEN-ENDED TIMING BELTS

Rubber base timing belts coming from sleeves for spiral cut belts and from press for straight cut belts. (RPP14 Steel cords).

- Very limited elongation
- Maximum traction load capacity

TRANSPORT PLATFORM

As part of the AS/RS systems, transport platforms shuttle the goods being stored from the lifting apparatus to the storage rack. Timing belts with high friction and wear-resistant covers move products to the dedicated storage location.

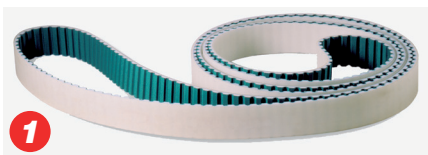
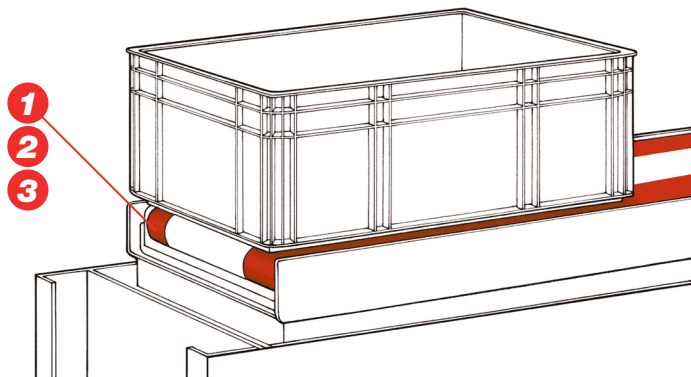

MEGAFLEX

Truly endless timing belts with thermoplastic polyurethane and high-strength helically wound zinc coated Steel tension members.

- Customized with special covers
- High friction
- Wear resistance
- Low elongation and high stability

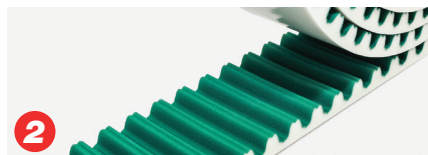

MEGALINEAR

Thermoplastic PU 92 ShA belts, supplied as open length rolls or as endless jointed belts; available in various tooth designs and cords. Recommended pitches: RPP14, AT20

- Low elongation
- Available special clean room treatment



SPECIAL RUBBER ENDLESS TIMING BELTS

Rubber endless timing belts made of high-quality rubber compounds, and high performance tension members.

- Customized with molded special covers (Durataq™)
- Good grip
- Wear resistance

ROLLER CONVEYORS

Timing belts or Poly-v ribbed belts are commonly used on roller conveyors. On the external side of the roller, power transmission belts deliver power from the motor to the main driven conveyor roller.

From this stage, rollers are interconnected by either timing belts or Poly-v ribbed belts, some of which can be produced with elastic-stretch properties.

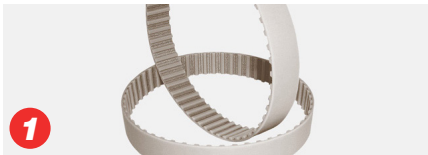
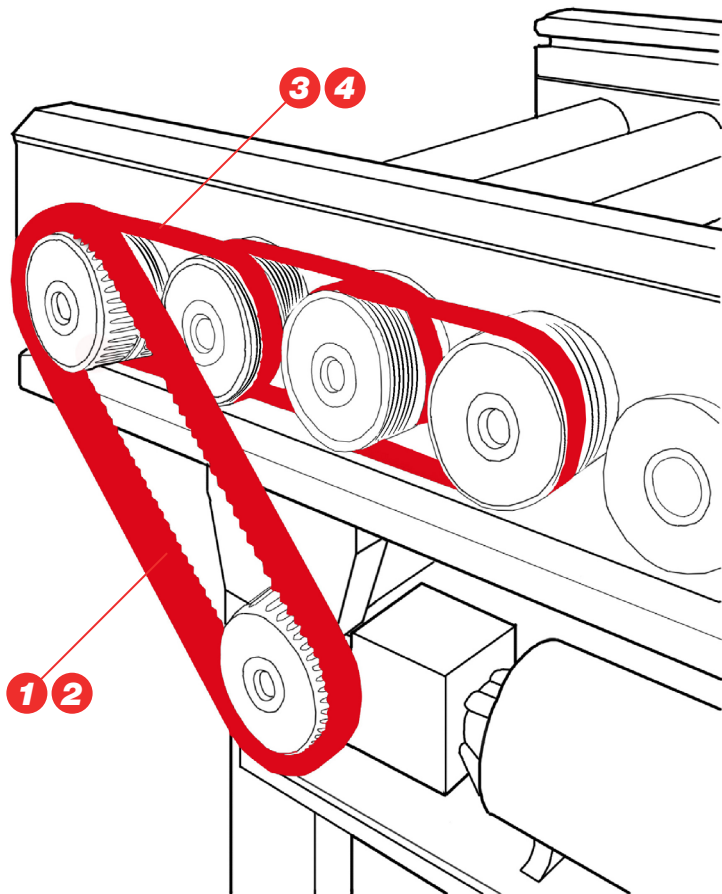

MEGAPOWER 2

Truly endless belt manufactured in thermoset polyurethane 88 ShA with high strength helically zinked Steel cord.

- High positioning precision and excellent dimensional stability
- Constant and high angular speed
- Superior wear and abrasion resistance
- Maintenance free



MEGADYNE MEGASYNC™ RUBBER ENDLESS TIMING BELTS

Rubber endless timing belts made of high-quality rubber compounds, and high performance tension members.

- Molded to length and pitch designation
- High performance
- Low noise



PV RUBBER RIBBED BELTS

Endless belts with longitudinal V-shaped grooves which combine the benefits of flat belts and V-belts. Supplied with standard or elastic cords, on request.

- High flexibility
- Improved power performance by increasing the number of ribs



MEGADYNE ROLLPOWER™

Elastic ribbed rubber belt designed to outperform on roller conveyors.

- Stable tension over time
- Smooth, reliable and quiet running
- Long life expectancy
- Speed up to 3 m/s
- Easy to install and replace

DIVERTERS

In today's warehousing and distribution environments, you can offload your products by means of diverters using high friction right angle transfer belts. Starting with a base synchronous belt, we offer a broad range of high friction cover surfaces. From MEGALINEAR joined polyurethane synchronous belts and MEGAFLEX truly endless polyurethane synchronous belts with TPU smooth covers to rubber synchronous belts with homogeneous covers along with specialty cover materials like Durataq® high friction.

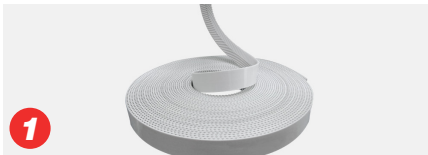
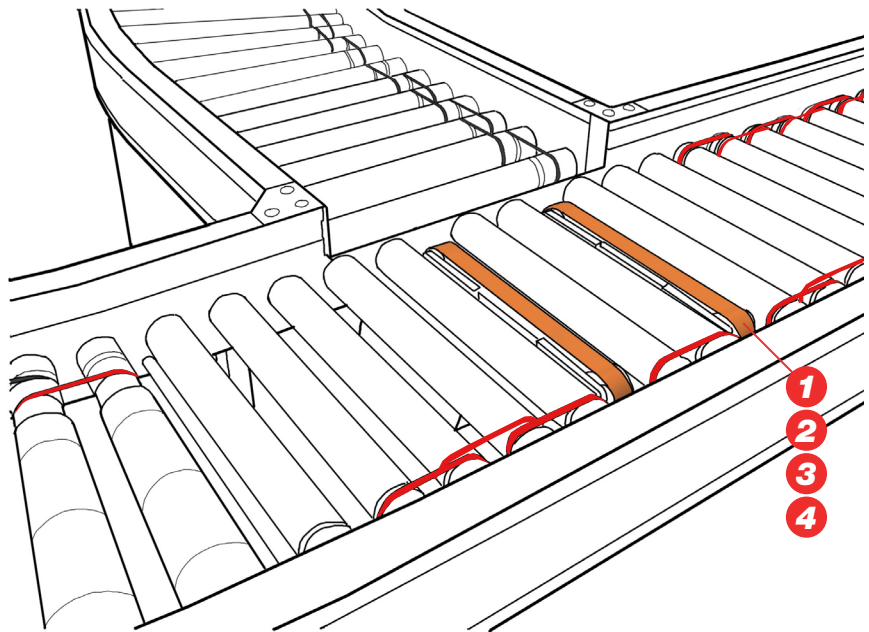

POLYURETHANE TIMING BELTS

Truly endless or joined timing belts with thermoplastic polyurethane with high strength helically wound zinc coated Steel tension members.

- Customized with special covers used to divert goods 90° from the starting direction of travel.
- Low elongation and high stability
- High friction and wear resistance.



SPECIAL RUBBER ENDLESS TIMING BELTS

Rubber endless timing belts made of high-quality rubber compounds, and high performance tension members.

- Customized with special covers (DuraTaq™ and Linatex®)
- Good grip



MEGADYNE ROLLPOWER™

Elastic ribbed rubber belt designed to outperform on roller conveyors.

- Stable tension over time
- Smooth, reliable and quiet running
- Long life expectancy
- Speed up to 3 m/s
- Easy to install and replace



MEGAWELD

Thermoplastic PU belts with different hardnesses and custom cross sections.

- High flexibility and grip
- Excellent resistance to aging and abrasion

OFFLOADING

Offloading and delivery conveyors typically rely on flat belts, however, multiple path polyurethane timing and rubber belts with high friction covers are also common. Special cover materials are available on belts where accumulation occurs.

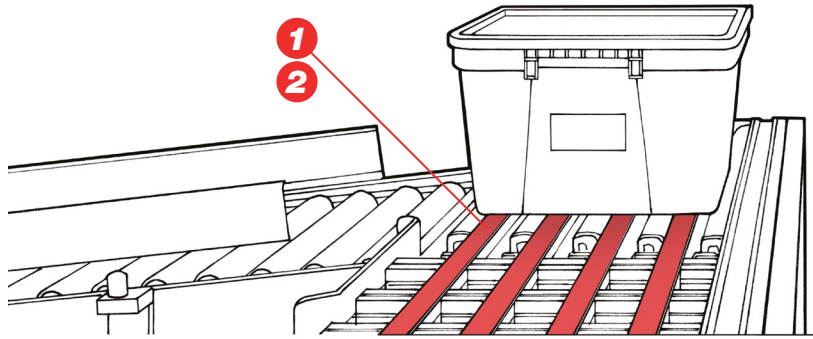

1 MOULDED RUBBER FLAT & SYNCHRONOUS

Rubber / polyurethane endless coated timing belts to maximize grip and durability over time.

- Equipped with special covers
- High friction and wear resistance



2 PU/RUBBER TIMING

Rubber / polyurethane joined coated timing belts to maximize grip and durability over time.

- Equipped with special covers
- High friction and wear resistance

RCS/RS ROBOT

Different types of toothed belts are used for the drives of robotic logistics systems.

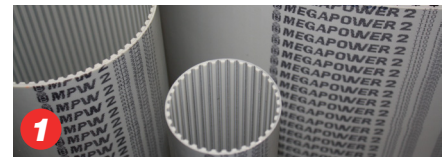
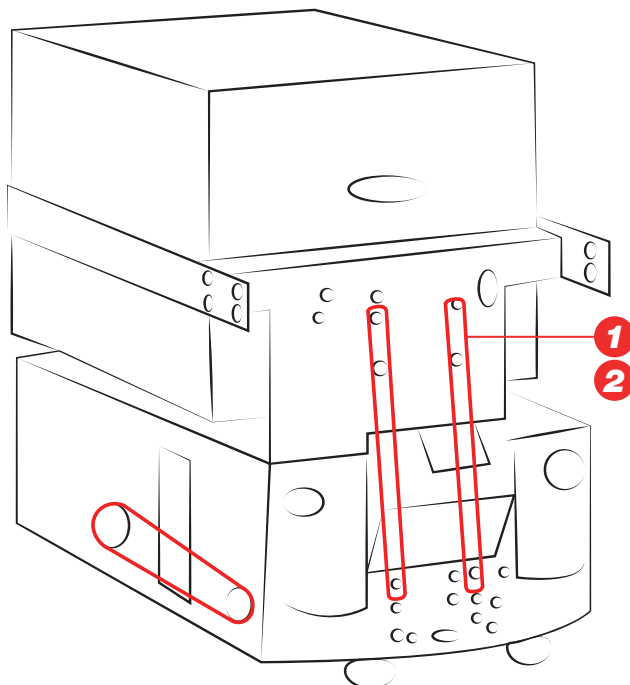

1 MEGAPOWER 2

Truly endless belt manufactured in thermoset polyurethane 88 ShA with high strength helically zinked Steel cord.

- High positioning precision and excellent dimensional stability
- Constant and high angular speed
- Superior wear and abrasion resistance
- Maintenance free



2 MEGADYNE MEGASYNC™ RUBBER ENDLESS TIMING BELTS

Rubber endless timing belts made of high-quality rubber compounds, and high performance tension members (RPP5, RPP8).

- High positioning precision and excellent dimensional stability
- Constant and high angular speed
- Superior wear and abrasion resistance
- Low noise

VERTICAL FARMING

Automation is used in many different areas to optimize the processes in Vertical Farming.

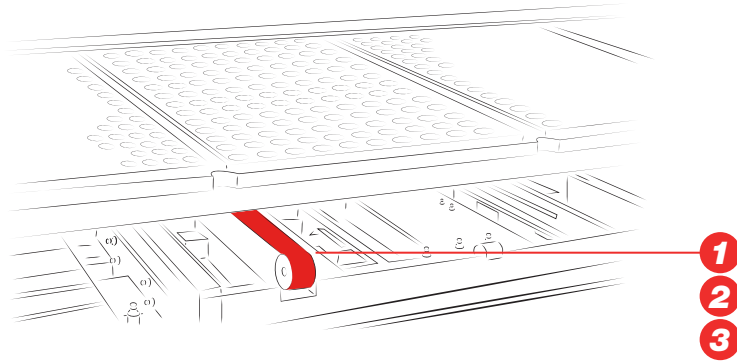

MEGALINEAR

Thermoplastic PU 92 ShA belts, supplied as open length rolls or as endless jointed belts; available in various tooth designs and cords (MTD14 XHP2, RPP14 XHP2, AT20).

- Constant dimension and length, improved accuracy
- Maintenance stop reduced during working time
- New Biobased design, on request

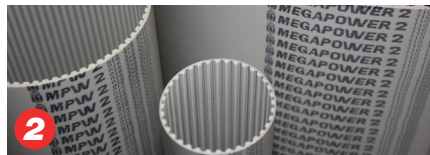

MEGAPOWER 2

Truly endless belt manufactured in thermoset polyurethane 88 ShA with high strength helically zinked Steel cord.

- High positioning precision and excellent dimensional stability
- Constant and high angular speed
- Superior wear and abrasion resistance
- Maintenance free



MEGADYNE MEGASYNC™ RUBBER ENDLESS TIMING BELTS

Rubber endless timing belts made of high-quality rubber compounds, and high performance tension members (RPP5, RPP8).

- High positioning precision and excellent dimensional stability
- Constant and high angular speed
- Superior wear and abrasion resistance
- Low noise

SCISSOR LIFT

The scissor lift is used in the vertical movement of the car frame ensuring hanger stability and individual height adjustment of the work zone.

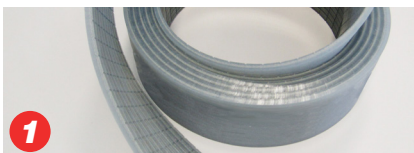

SPECIAL MEGALINEAR

Thermoplastic PU 92 ShA belts, supplied as open length rolls or as endless jointed belts, with special silicone-free compound.

- Suitable for painting process
- Contaminant free
- Silicone free

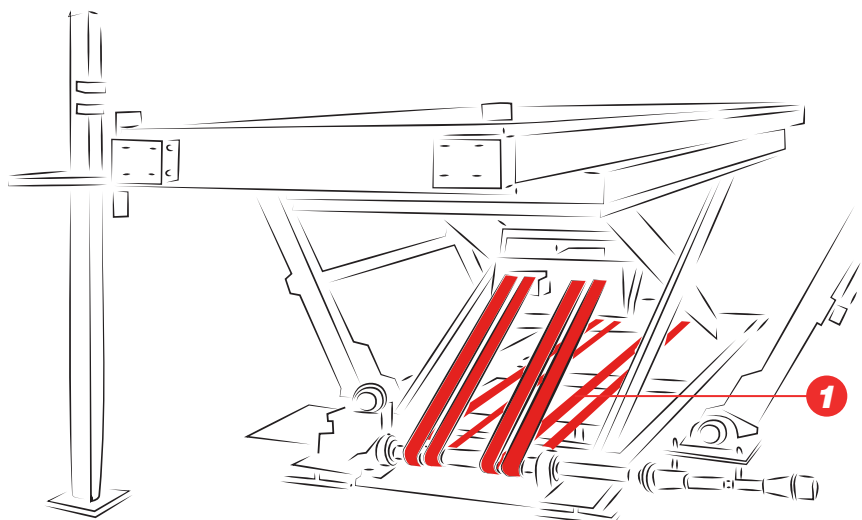

INDUSTRIAL CAR LIFT

High-strength belts in car elevators are used to vertically transport vehicles alongside different floors inside buildings both in automotive production plants and car parking areas.

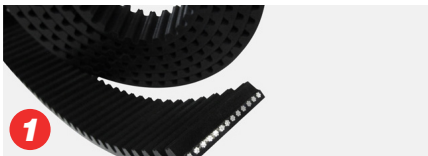
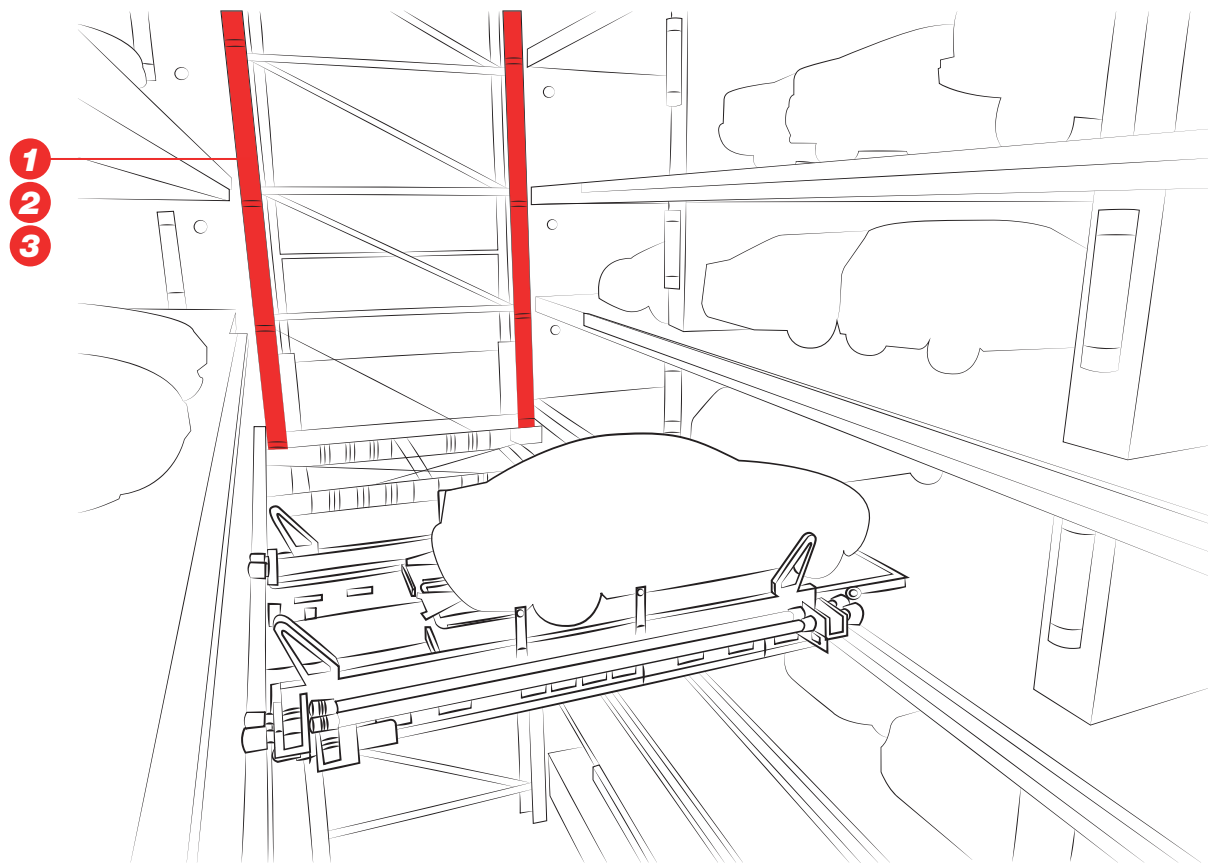

MEGALINEAR

Thermoplastic PU 92 ShA belts, supplied as open length rolls or as endless jointed belts; available in various tooth designs and cords (MTD14 XHP2, RPP14 XHP2, AT20).

- Constant dimension and length, improved accuracy
- Maintenance stop reduced during working time
- New Biobased design, on request

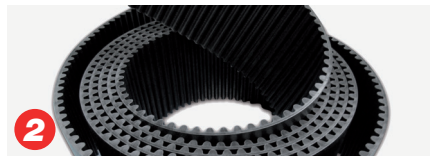

MEGALINEAR GW

High-performance thermoplastic polyurethane timing belts with Steel zinc coated cords (14M, 20M.)

- High transmittable power under continuous substantial loads
- Greater breaking strength
- High tooth resistance



MEGALINEAR QST

Open-ended polyurethane timing belts, self-tracking due to the offset helical tooth design (8M, 14M).

- High torque capacity
- Low noise
- Positive engagement in Bi-directional lift applications

PAINTING LINE

Flat and toothed belts are used for vertical and horizontal movement of the car frame during the production process.

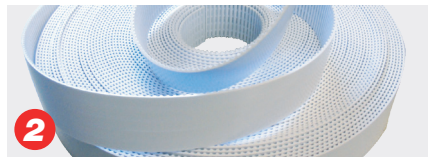
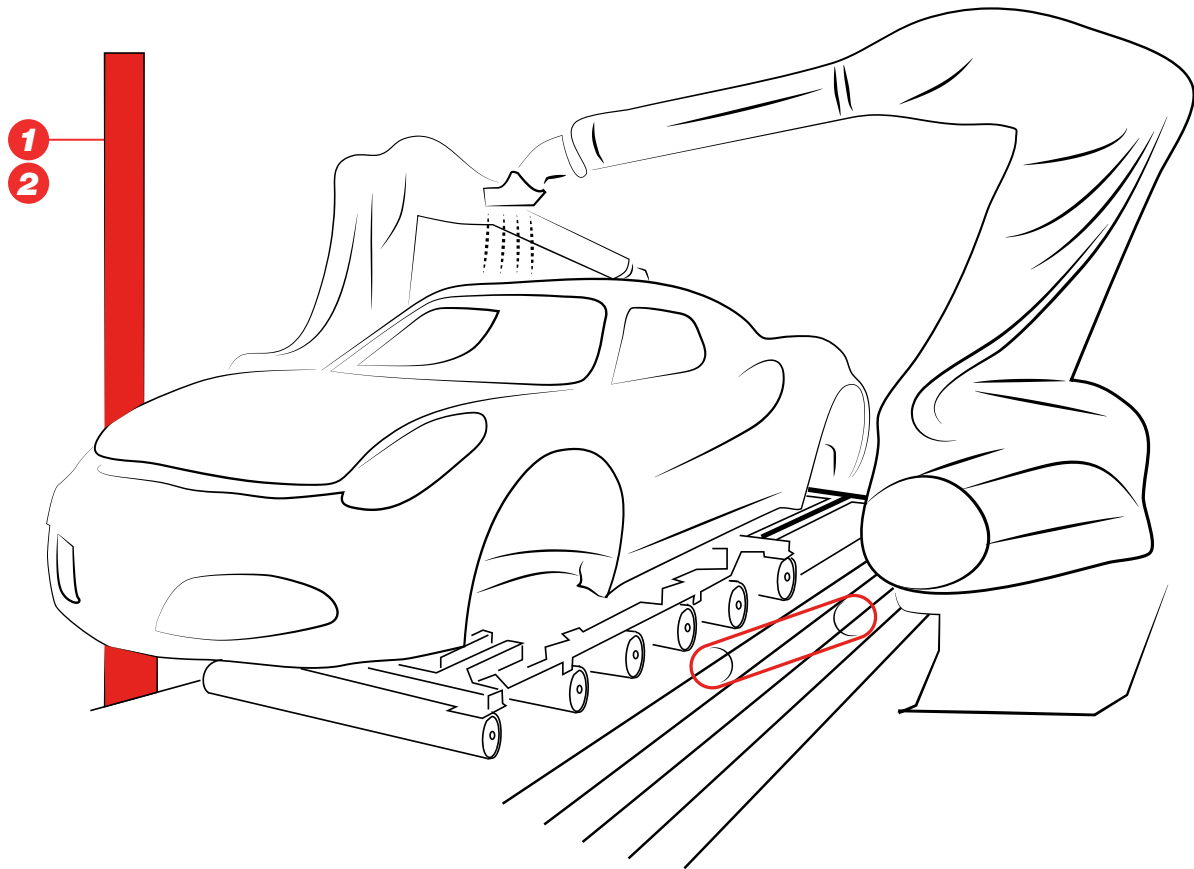

MEGAPAIN

Rubber endless timing belt designed for painting lines and made of NBR-based compound with a high purity degree and without contaminating agents, as requested for water or solvent-based paints.

- Supplied in special sealed packaging
- Silicone Free
- High tooth resistance

MEGALINEAR SILICONE FREE

Thermoplastic PU belts, 92 ShA, supplied as open length rolls or as endless jointed belts; available in various tooth designs and cords with special silicone-free compound.

- Suitable for painting process
- Contaminant free

SHEET METAL PROCESSING

Multi belts system in order to convey the metal sheet: the alternation of standard belts and vacuum belts is used to increase the positional and grip accuracy.

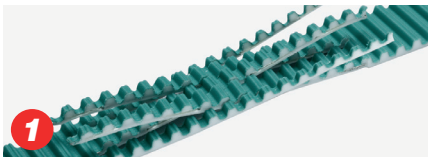
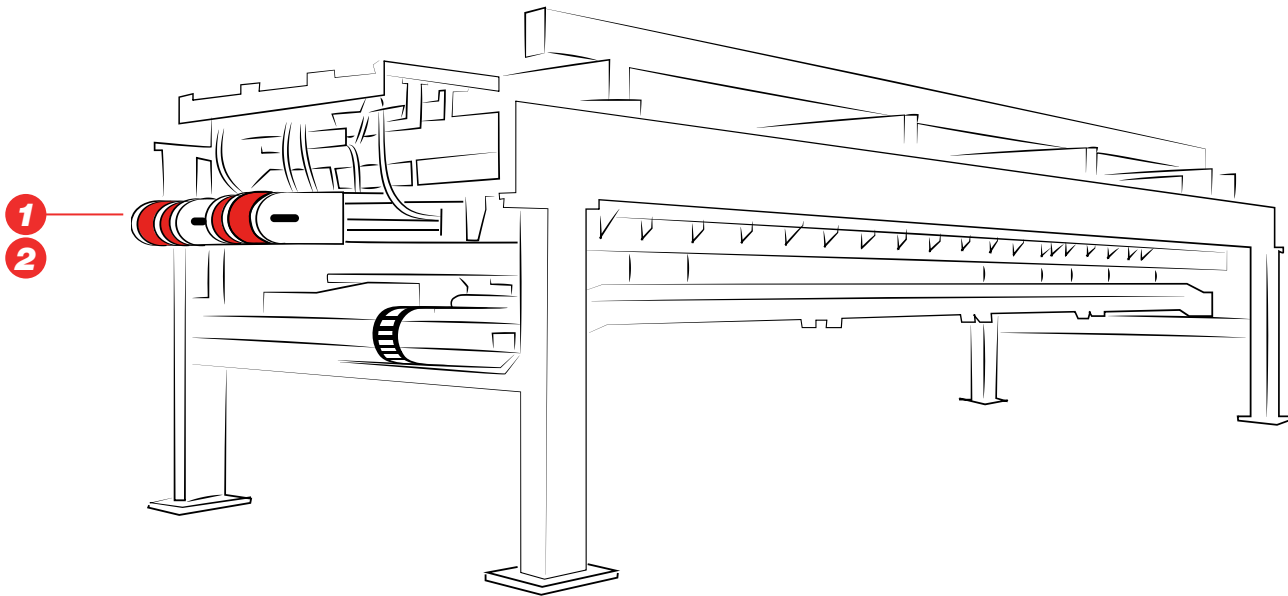

MEGALINEAR

Thermoplastic PU 92 ShA belts with S & Z parallel cords. Supplied as open length rolls or as endless jointed belts; available in various tooth profiles and cords.

- Suitable for high speed conveying
- Available with special polyurethane and covers for oil, chemical resistance and high grip requirements
- Non-marking surface materials
- Available silicone free

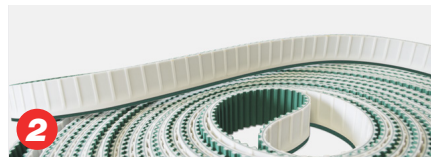

MEGAFLEX

Truly endless timing belts with thermoplastic polyurethane and high strength helically wound zinc coated steel tension members.

- Low elongation and high stability
- Suitable for high speed and heavy conveying
- Available with special covers and non-marking surface materials

CAR FRAME TRANSLATOR

Timing belts are used in the frame rotation during the car production process.

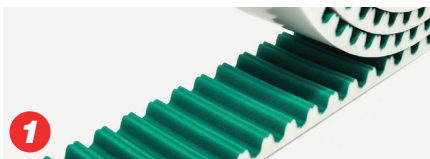
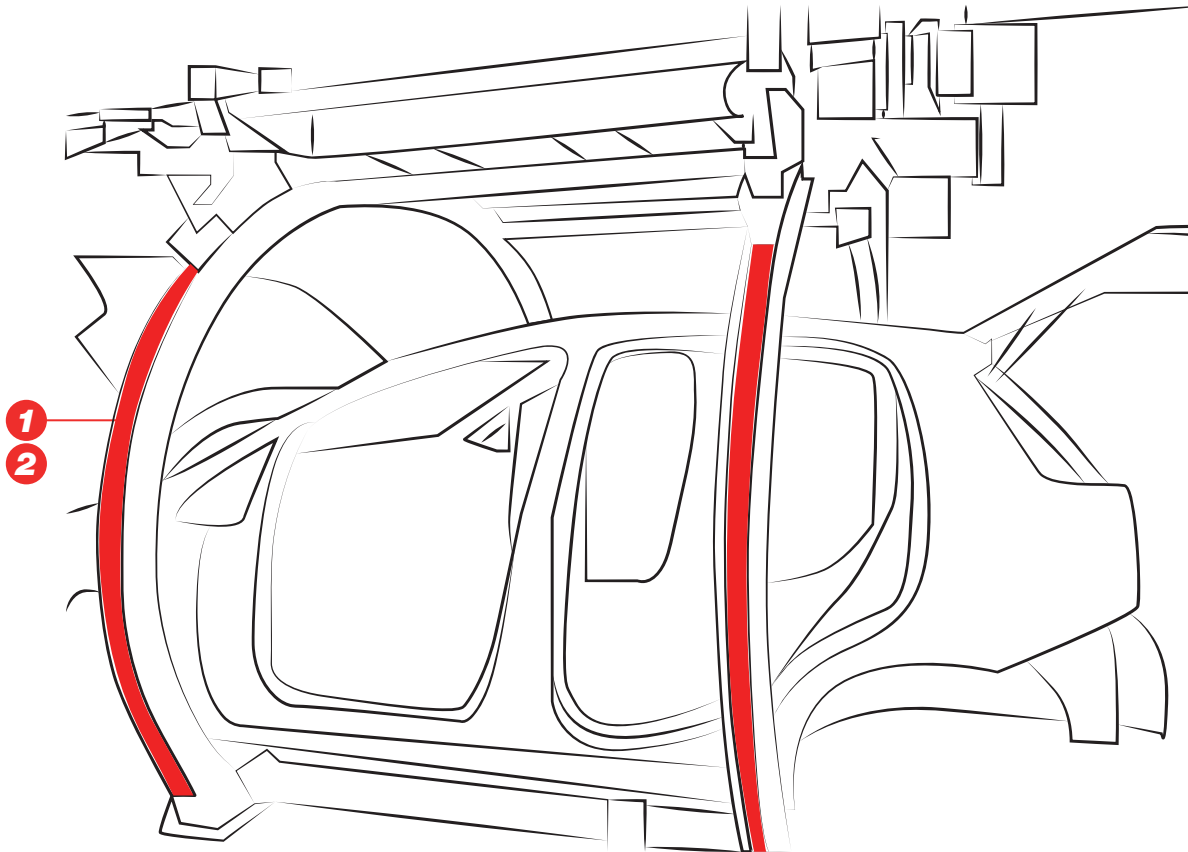

MEGALINEAR

Thermoplastic PU 92 ShA belts, supplied as open length rolls; available in various tooth designs and cords.

- High positioning precision suitable for linear movement and lifting systems
- Maximum traction load capacity



MEGAFLEX

Truly endless timing belts with thermoplastic polyurethane and high-strength helically wound zinc coated Steel tension members.

- Customized with special covers
- High friction
- Wear resistance
- Low elongation and high stability

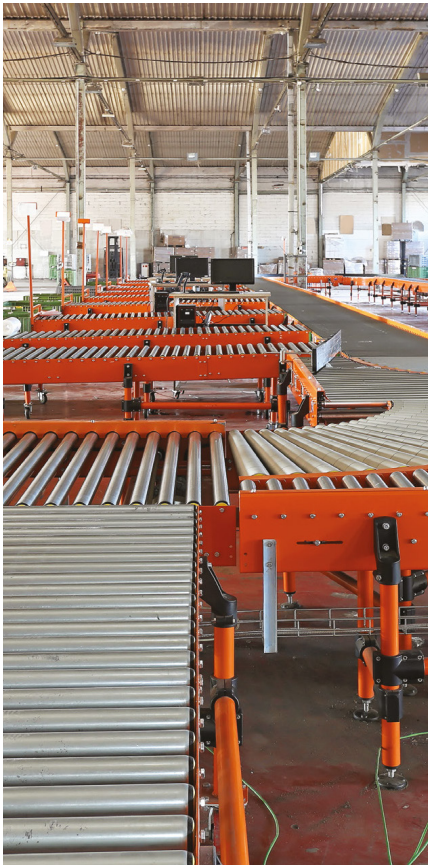

CASE STUDY

APPLICATION: Warehouse sorting line

PREVIOUS SOLUTION: Competitor's Elastic Poly V belt

CHALLENGE WITH THIS SYSTEM: Lifetime of the belt and high energy use

MEGADYNE SOLUTION: MEGADYNE ROLLPOWER™ BELT (314 PJ2)

Reduces energy consumption by 5% and increases production by drastically reducing maintenance for an industrial sector where reliability is the real driver of the market.

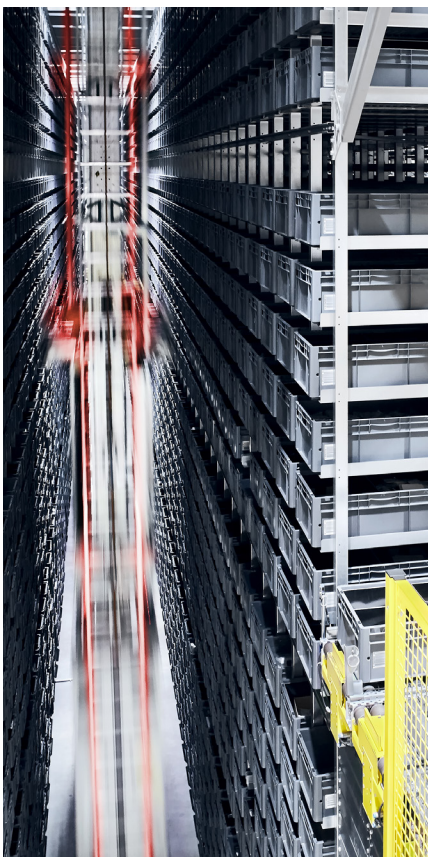

CASE STUDY

APPLICATION: Automatic Warehouse

PREVIOUS SOLUTION: Chain drives

CHALLENGE WITH THIS SYSTEM:

- Noisy
- Harsh, inaccurate movement
- Unable to move heavy loads with a high safety factor in a reduced space

MEGADYNE SOLUTION: MEGALINEAR QST14 XHP STEEL CORD

- Accurate product movement
- Improved reduction in noise level
- High dimensional stability and torque capacity
- Compact drive
- Self-tracking properties (eliminating the need for pulley flanges)
- Lighter weight and lower inertia than chain drives

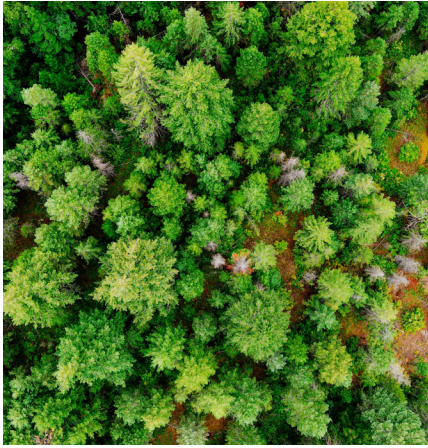

ABOUT SUSTAINABILITY

Sustainability has always been a guiding principle for Ammega and all members of Ammega Group. We are proud to work with **EcoVadis** to monitor and evaluate our environmental, social and ethical performance.

At Megadyne, we are committed to becoming more and more responsible towards the world by reducing our impact on the planet. We work on new technological raw materials made by partners using the most ecological sustainable technologies. Our team has been working on the continuous improvement of products, services, and solutions for the benefit of society and the environment. Our vision is to be the local partner of choice for sustainable belting solutions around the globe.

CERTIFICATIONS



All Megadyne polyurethane power transmission belts comply with ISO 14001, ISO 9001 and European RoHS Directive. The belts are made with raw materials in compliance with REACH standards, meaning that all belts, pulleys, toothed bars, couplings blocking units and other items supplied by Megadyne do not contain one (or several) of the SVHC in Candidate List above a concentration of 0.1% w/w.

All Megadyne rubber power transmission belts are made in accordance with the Quality Management System Standard: ISO 9001:2015 and ISO 14001:2015. These certificates are valid for the following field of application: design, manufacture and sale of power transmission belts. Marketing of transmission and transport elements (pulleys, tensiometers).

MEMBERSHIPS



For more information, scan the QRCode and discover our interactive infographics dedicated to the Material Handling



Discover Your Local Contacts

The local partner of choice
for sustainable power transmission belting solutions
around the globe.



Scan the QR code
and find your local
contact

General contact information:

Megadyne

Via Trieste, 16

Via S. Lucia 114 - 10075 Mathi (Torino)

Italy

megadynegroup.com

