

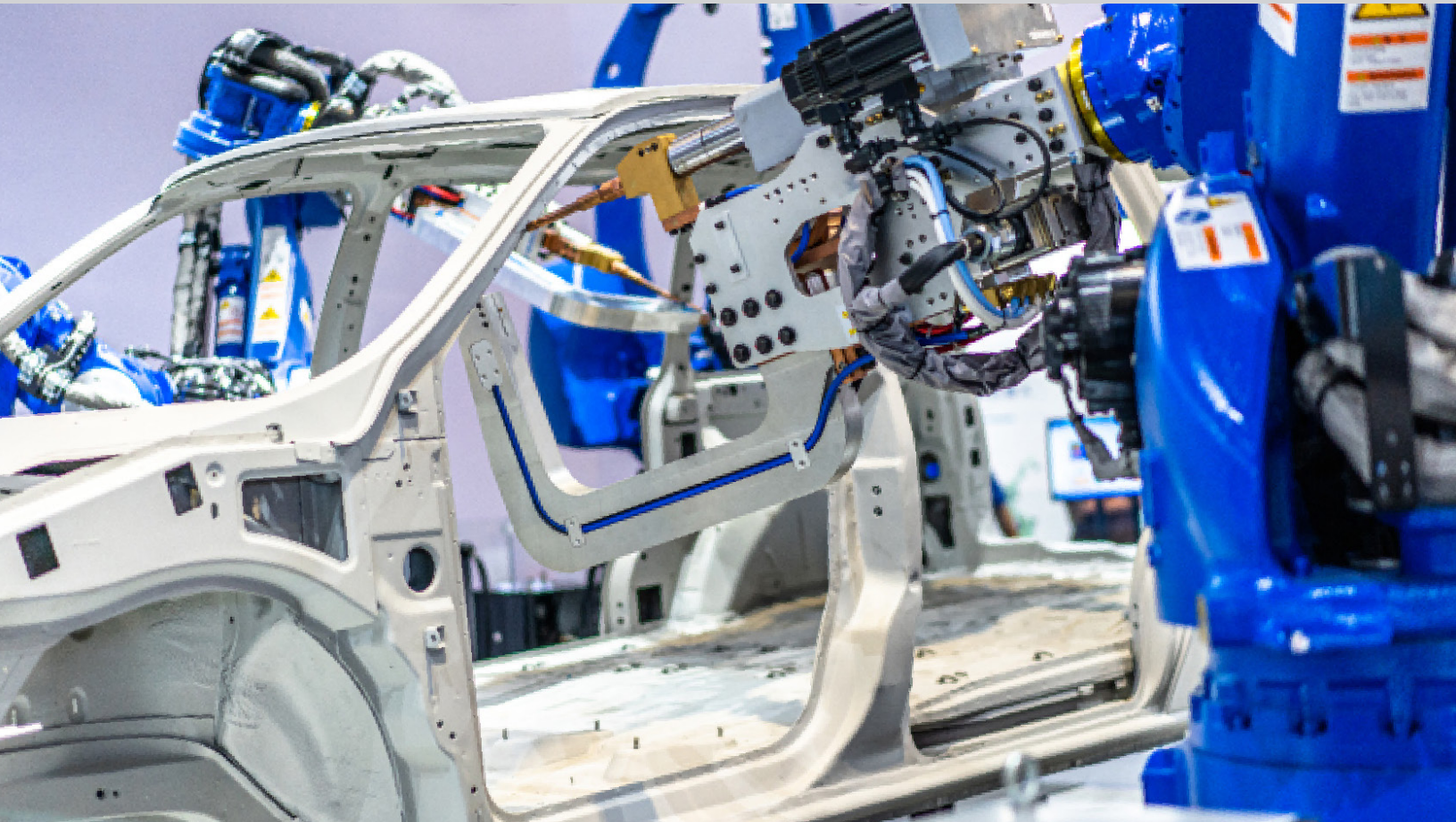

**MEGADYNE**



***AUTOMOTIVE  
& TIRE  
PRODUCTION  
LINE***

*AM-EN*

INDUSTRY  
BROCHURE



# AUTOMOTIVE INDUSTRY

Due to the years of experience in the automotive and tire industry and the ongoing research, we offer a wide range of both standard and customised solutions. Our Research & Development experts have come up with special materials that withstand extreme working conditions and aggressive chemicals. Silicone-free timing belts, for instance, are fundamental in the automotive painting process. For years, we have been working hand in hand with our partners from the automotive and tire sector, observing their need for vacuum, magnetic applications, and the transport of the raw rubber stock. Your experience in these fields inspired us to develop adjusted solutions.

Megadyne has been catering to your needs since 1957, designing and manufacturing power transmission belts, matched components, and complete belt systems for all types of equipment. We are a reliable partner for original equipment manufacturers and aftermarket distributors, with:

9 manufacturing plants in Europe, North America, and Asia, more than 170 Customer Solution Centres and 3 main distribution hubs around the world, able to deliver products efficiently, from large industrial sites to remote locations.

## BELT PROPERTIES



MEGADYNE MEGASYNC™ (RPP)	
SUPPLIED AS	Endless
LENGTH	248 - 4 956 mm
WIDTH	12 - 170 mm*
PITCH	RPP8 - RPP14
TENSION MEMBER	Fiberglass
FEATURES	High stability and resistance; antistatic

*\*Standard Width Range - Megadyne will cut to desired width upon request.*



MEGADYNE MEGAPAINT	
SUPPLIED AS	Endless
LENGTH	248 - 4 956 mm
WIDTH	12 - 170 mm*
PITCH	RPP8
TENSION MEMBER	Fiberglass
FEATURES	Silicone and contaminants free



MEGADYNE MEGAFLEX PS4.8	
SUPPLIED AS	Endless
LENGTH	1 900 - 22 770 mm
WIDTH	80 mm
PITCH	PS4.8
TENSION MEMBER	Steel cord
COATINGS	NFT
FEATURES	High resistance to wearing and reduction of the maintenance costs



### MEGADYNE MEGASYNC™ TITANIUM

SUPPLIED AS	Endless
LENGTH	248 - 4 956 mm
WIDTH	12-170 mm
PITCH	TTM8, TTM14
TENSION MEMBER	Special Carbon cord
FEATURES	Compact drive package; high stability and resistance

\*Standard Width Range - Megadyne will cut to desired width upon request.



### MEGADYNE V-BELT

SUPPLIED AS	Endless - Wrapped - Raw edge
LENGTH	450 - 12 530 mm
SECTIONS	Wrapped SPZ, SPA, SPB, SPC; Raw edge XPZ, XPA, XPB, XPC
TENSION MEMBER	Polyester
FEATURES	Long lifetime and small pulley diameters



### MEGADYNE ACCU-LINK®

SUPPLIED AS	Rolls
LENGTH	7 - 30 m
SECTIONS	Z/3L - A/4L - B/5L - C
FABRIC	Multi-layer woven polyester
FEATURES	Fast and easy installation; durability; any length possible



### MEGADYNE POLYURETHANE WIDE BELTS

SUPPLIED AS	Open-ended rolls - Joined
LENGTH	from 1.2 m
WIDTH	200 - 500 mm
PITCH	T5, T10, H
TENSION MEMBER	Kevlar®
COATINGS	NFT - NFB
FEATURES	High precision and convey capability



### MEGADYNE POLYURETHANE TIMING BELTS

SUPPLIED AS	Open-ended Roll - Endless - Joined - PPJ
LENGTH	MEGALINEAR: 0.5 - 100 m MEGAFLEX: 1.5 - 22.77 m
WIDTH	6 - 150 mm
PITCH	T5, T10, T20, AT5, AT10, AT20, RPP8, RPP14, MTD8, MTD14, TG10, ATG10, TG20, ATG20, P4
TENSION MEMBER	Steel - HP - HF - HPF - Stainless Steel - Kevlar®
COATINGS	AVAFC - TENAX - RED GRIP - NFT
FEATURES	High resistance belts available also in silicone-free compounds and various custom made solutions for high performance level



# SPECIAL COVERS AND MODIFICATIONS

## AVAFC 60/70/85

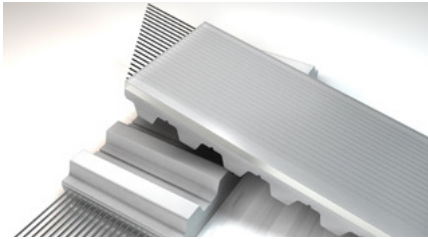

MATERIAL Polyurethane  
COLOUR Transparent

Excellent cut and wear resistance and good oil resistance.

## TENAX STANDARD / TENAX 40

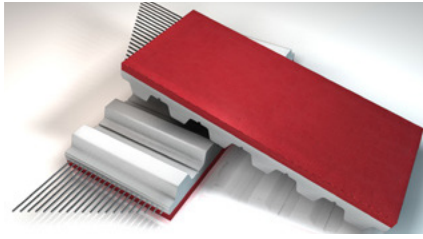

MATERIAL Natural Rubber  
COLOUR Red

High Grip with good wear resistance.

## RED GRIP

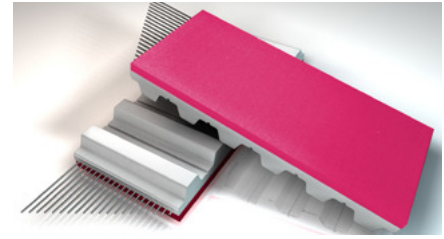

MATERIAL PU/Synthetic Rubber  
COLOUR Red

A seamless alternative to LINATEX™. Only available on MEGAFLEX.

## NFB/NFT

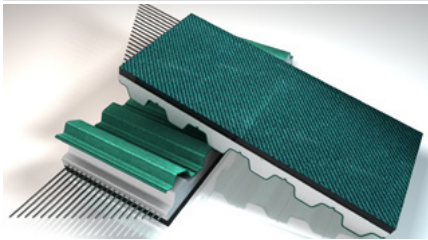

MATERIAL Nylon Fabric  
COLOUR Green

NFT/NFB offers low friction for accumulation as well as low noise benefits and is usually applied coextrusion on base belts.

## LUG GRIND

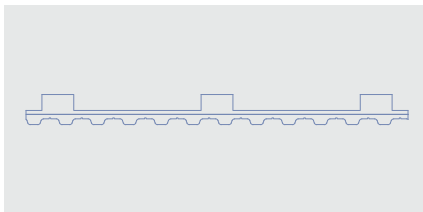

## COUNTERSINKS WITH HOLES



# METAL DRIVE COMPONENTS

Use an extensive range of pulleys and accessories like timing bars, flanges, clamping plates, couplings to design a complete drive transmission system.

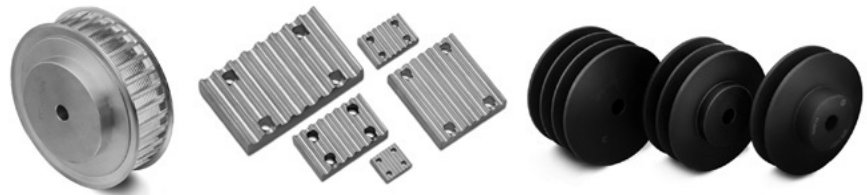

# SHEET METAL PROCESSING

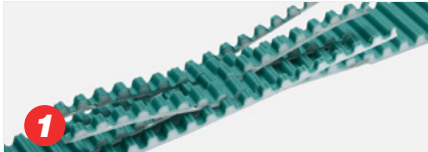
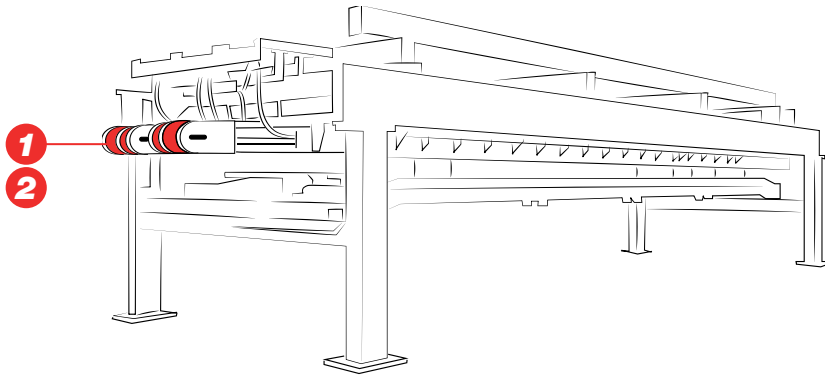

## MEGALINEAR

Thermoplastic PU 92 ShA belts with S & Z parallel cords. Supplied as open length rolls or as endless jointed belts; available in various tooth profiles and cords.

- Suitable for high speed conveying
- Available with special polyurethane and covers for oil, chemical resistance and high grip requirements
- Non-marking surface materials
- Available silicone free

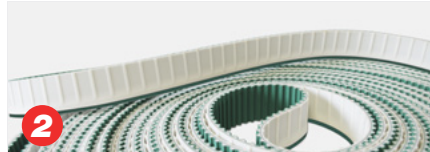

## MEGAFLEX

Truly endless timing belts with thermoplastic polyurethane and high strength helically wound zinc coated steel tension members.

- Low elongation and high stability
- Suitable for high speed and heavy conveying
- Available with special covers and non-marking surface materials

# ROBOTIC MANUFACTURING

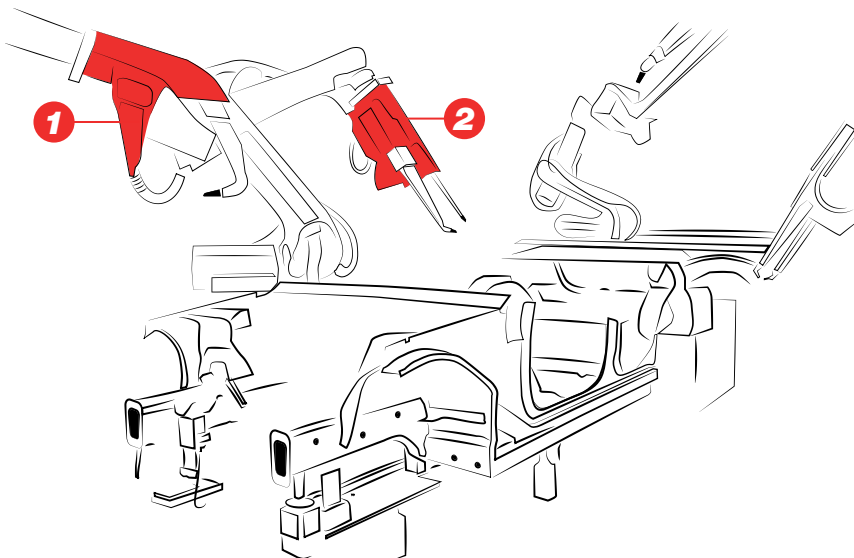

## MEGAPOWER 2

Truly endless belt manufactured in thermoset polyurethane 88 ShA with high strength helically zinked steel cord.

- High positioning precision and excellent dimensional stability
- Constant and high angular speed
- Superior wear and abrasion resistance
- Maintenance free



## MEGADYNE MEGASYNC™

Rubber endless timing belts made of high-quality rubber compounds and spiral fiberglass tension members (RPP)

- High speed
- High precision drives

# GLASS TEMPERING LINE AND STORAGE



## POLYURETHANE NON-MARKING TIMING BELTS

Truly endless or joined timing belts with thermoplastic polyurethane with high strength helically wound zinc coated steel tension members.

- Customized with special non-marking covers: AVAFC (urethane) and Z cover (Foam urethane)
- Non marking
- Smooth drive
- High friction

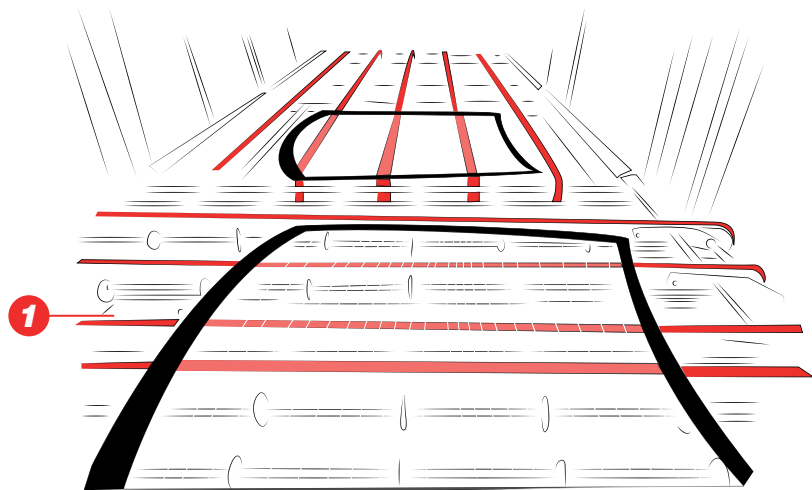

# FAN SYSTEM

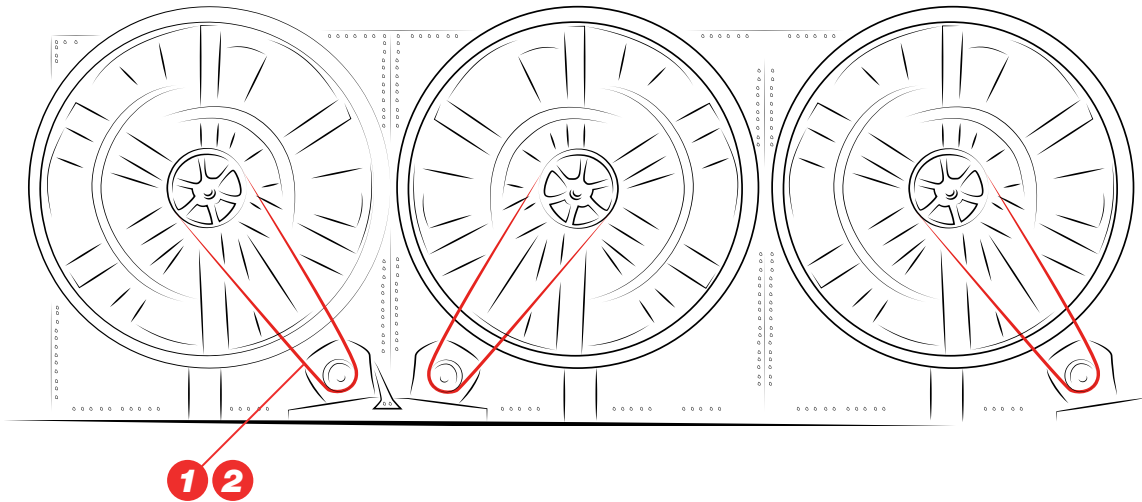

## V-BELT

V-belts, made of polybutadiene compound in a wide variety of sizes and sections.

- Grinded sidewalls for smooth-running operation, with no vibrations and reduced noise levels
- Long and reliable service life
- Reduced operational cost



## ACCU-LINK®

Link-belt, created and developed as an alternative to classical rubber V-belts, made with a polyurethane elastomer reinforced by a multilayer woven polyester fabric.

- Easy belt assembly
- Available in sections A, B, C
- Low vibration level

# CAR CHASSIS ASSEMBLY AND HANDLING

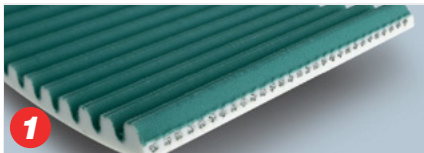
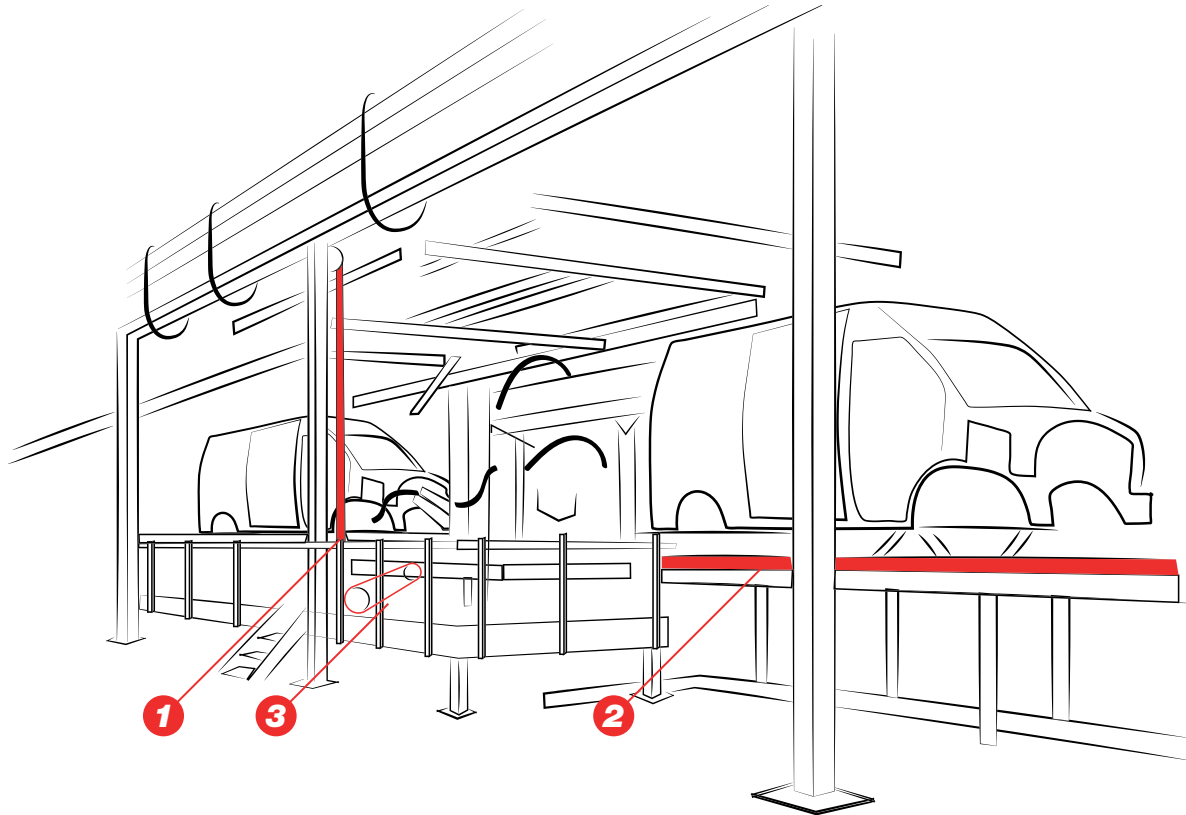

## MEGALINEAR

Thermoplastic PU 92 ShA belts with S & Z parallel cords. Supplied as open length rolls or as endless jointed belts; available in various tooth profiles and cords. (RPP14, RPP14 XHP2; P3, P3.3 and P4).

- Designed to ensure a precise position on heavy loads
- Available in several widths and with different tensile members
- Available silicone free



## MEGAFLEX FLAT BELT

Truly Endless Flat belts (PS4.8) with thermoplastic polyurethane and high-strength helically zinked steel tension members.

- Specifically developed for chassis production
- Suitable for skid conveyors applications



## MEGASYNC™ TITANIUM

Top of the line rubber endless timing belts, with superior power and torque drives capacity, even in the most extreme operating conditions (TTM8, TTM14).

- Compact drive package
- High stability and resistance
- Long life cycles, cost-efficiency

# PAINTING LINE

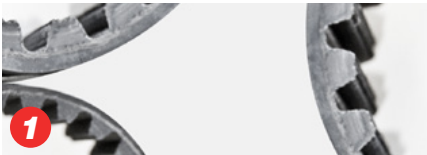
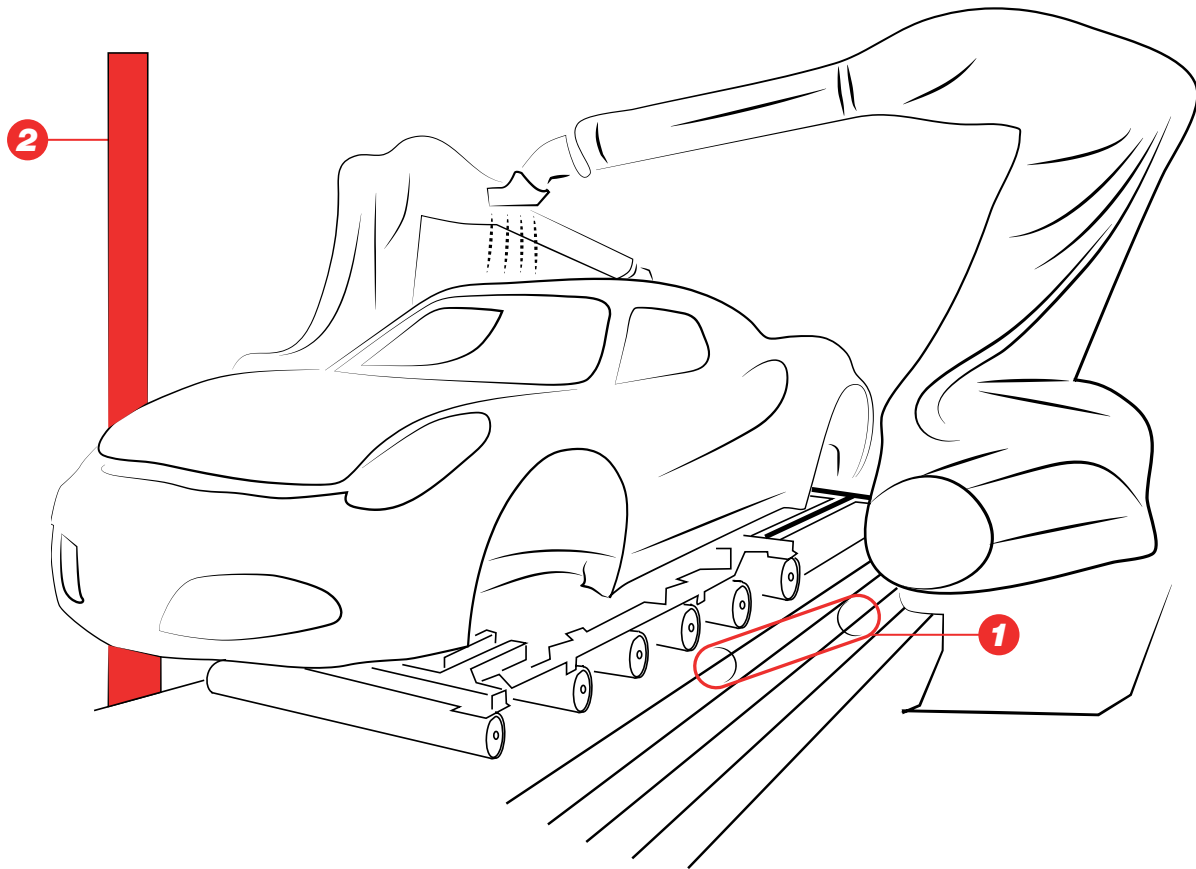

## MEGAPAINT

Rubber endless timing belt designed for painting lines and made of NBR-based compound with a high purity degree and without contaminating agents, as requested for water or solvent-based paints.

- Supplied in special sealed packaging
- Silicone free

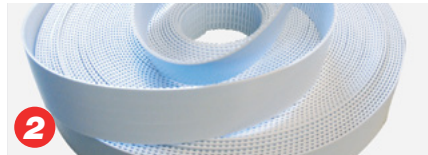

## MEGALINEAR SILICONE FREE

Thermoplastic PU 92 ShA belts, supplied as open length rolls or as endless jointed belts, with special Silicone-free compound.

- Suitable for painting process
- Contaminant free
- Silicone free



# TIRE MANUFACTURING

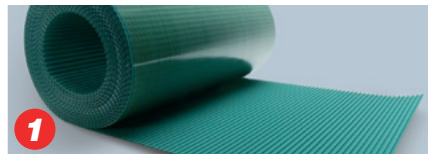
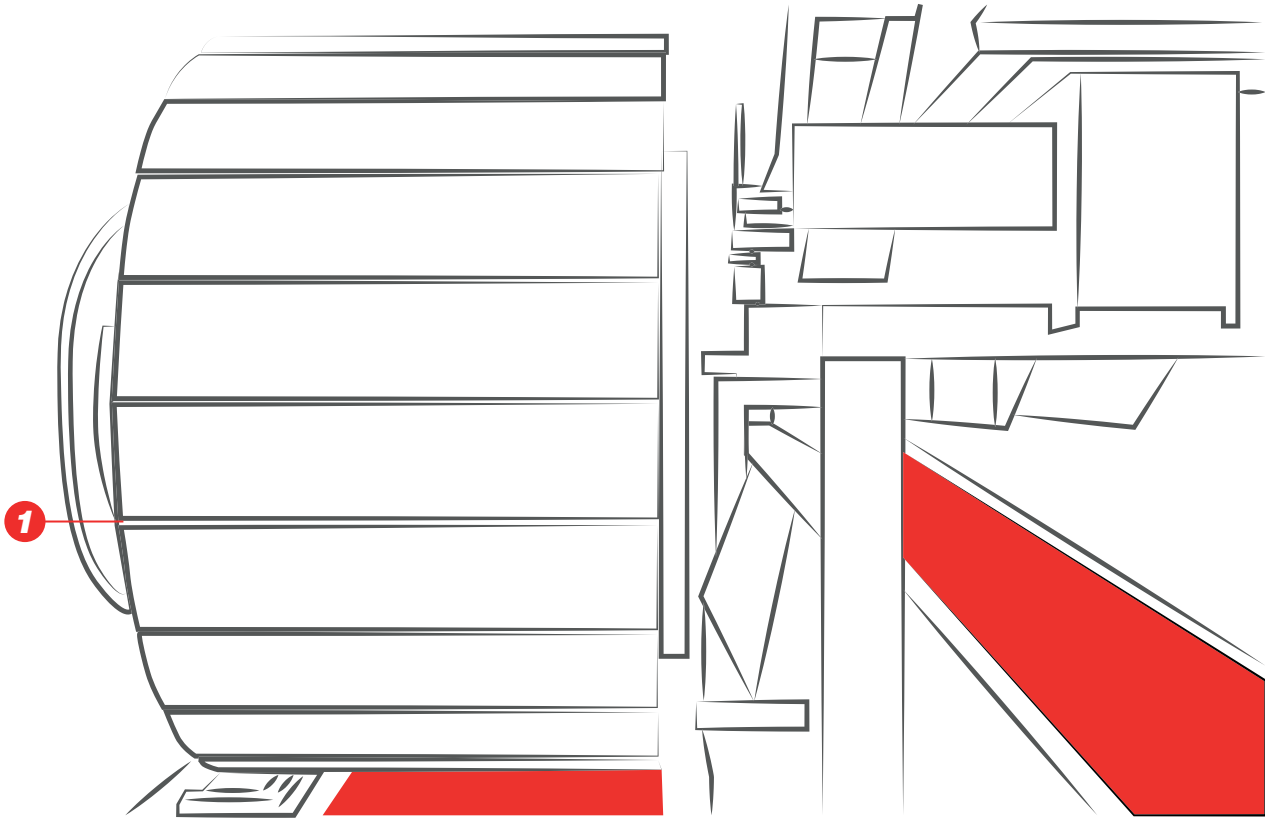

## MEGALINEAR WIDE

Wide transparent thermoplastic 92 ShA PU belts, Kevlar® cord. Supplied as open length rolls or as endless jointed belts; only available in H, T5 and T10 pitches.

- Synchronized conveying with low friction conveying surface.
- Joining process insures perfect flatness
- Width up to 500 mm



## CASE STUDY

APPLICATION: Roller system for heavy duty van frames

PREVIOUS DRIVE: Rubber FLAT BELTS

PREVIOUS DRIVE PROBLEMS: High quantity of dust particles and necessity of frequent maintenance

### SOLUTION

**PS4.8** eliminated the problem of the powder and increased significantly the lifetime of the belt. The customer did not report failures and strongly reduced the maintenance actions.

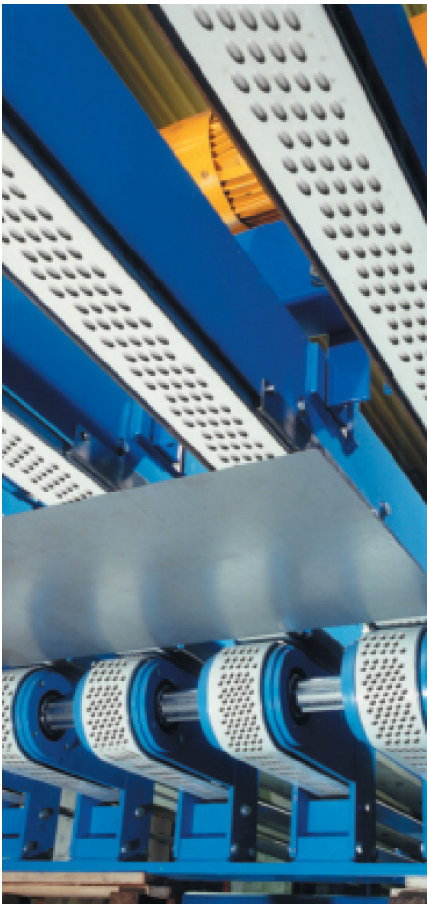

## CASE STUDY

APPLICATION: Vacuum conveying systems

PREVIOUS DRIVE: Polyurethane standard belt joined T20 with 85 ShA PU over thickness

PREVIOUS DRIVE PROBLEMS: Low resistance to synthetic oils used in the application

### SOLUTION

Special polyurethane cover made in high chemical resistance material. Megadyne increased by five times the resistance and the lifetime of the belts in the same conditions.

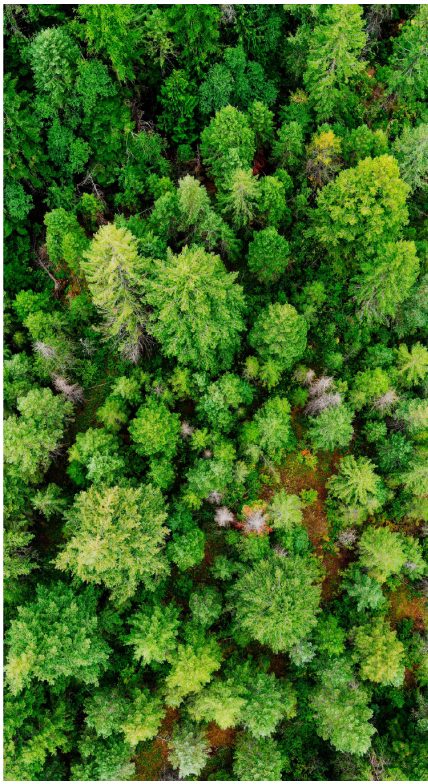

# ABOUT SUSTAINABILITY

Sustainability has always been a guiding principle for Ammega and all members of Ammega Group. We are proud to work with EcoVadis to monitor and evaluate our environmental, social and ethical performance.

At Megadyne, we are committed to becoming more and more responsible towards the world by reducing our impact on the planet. We work on new technological raw materials made by partners using the most ecological sustainable technologies. Our team has been working on the continuous improvement of products, services, and solutions for the benefit of society and the environment. Our vision is to be the local partner of choice for sustainable belting solutions around the globe.

Important sustainability achievements include improvements throughout the supply chain and in tracking our carbon footprint as well as the launch of new sustainable solutions for our clients. Major steps forward on sustainable investments are slowly bringing us closer to goals set in the Paris Agreement. We are on a journey towards a sustainable future, continually revising our plans and raising the level of our ambitions wherever possible. Our business performance and successes are key factors in defining our impact on the economic, social, and natural environment. We take the responsibility for this impact for all stakeholders and make every endeavour strengthen our roles as conscientious corporate citizens.

# CERTIFICATIONS



All Megadyne polyurethane power transmission belts comply with ISO 14001, ISO 9001 and European RoHS Directive. The belts are made with raw materials in compliance with REACH standards, meaning that all belts, pulleys, toothed bars, couplings blocking units and other items supplied by Megadyne do not contain one (or several) of the SVHC in Candidate List above a concentration of 0.1% w/w.

All Megadyne rubber power transmission belts are made in accordance with the Quality Management System Standard: ISO 9001:2015 and ISO 14001:2015. These certificates are valid for the following field of application: design, manufacture and sale of power transmission belts. Marketing of transmission and transport elements (pulleys, tensiometers).

# MEMBERSHIPS



# Discover Your Local Contacts

The local partner of choice  
for sustainable power transmission belting solutions  
around the globe.



**General contact information:**

**Megadyne**

Via Trieste, 16  
Via S. Lucia 114 - 10075 Mathi (Torino)  
Italy

[megadynegroup.com](http://megadynegroup.com)



Scan the QR code  
and find your local  
contact

